

# GREAT SOUTHERN AND WESTERN RAILWAY

IRELAND

III  
162

Planche 10.

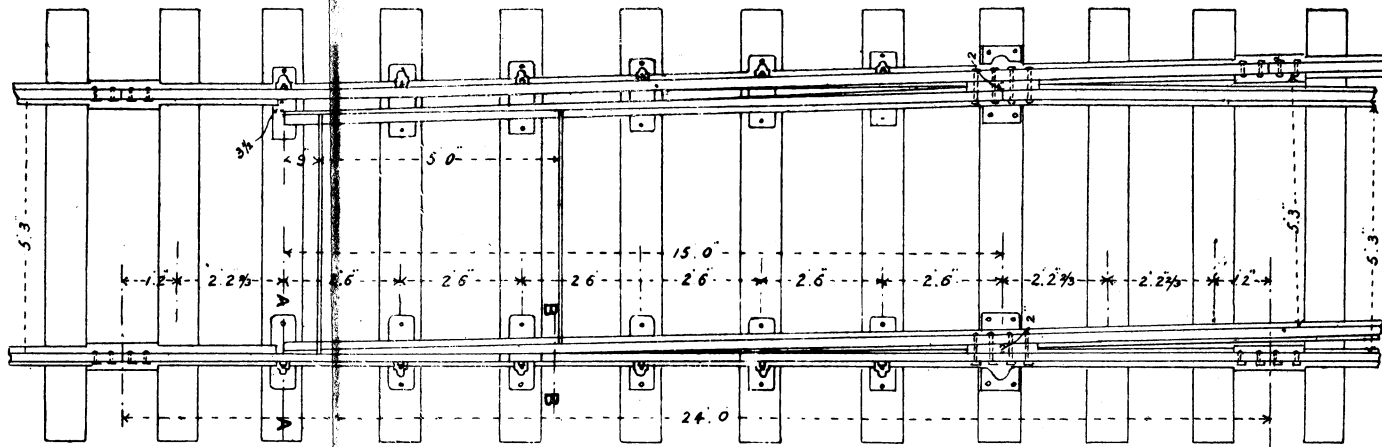

Fig 1  
15'0" POINTS AND STOCK RAILS

*Explication des termes anglais :*

15'0 points and stock rails = Aiguille de 4.57 m.  
et rail contre-aiguille. — Section AA half size  
= Demi-grandeur. — Section BB half size =  
Demi-grandeur.

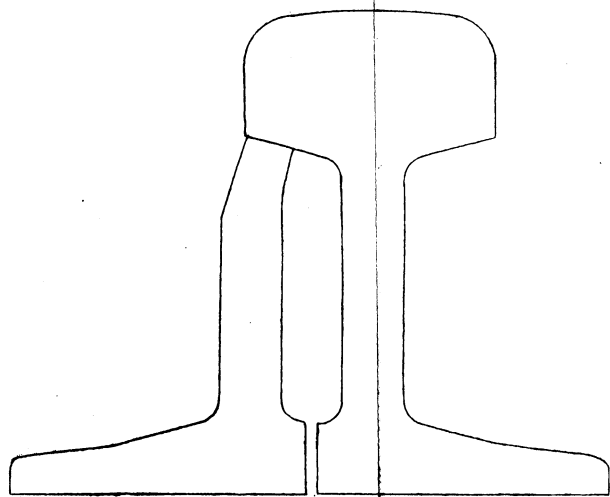

Fig 2  
SECTION AA HALF SIZE

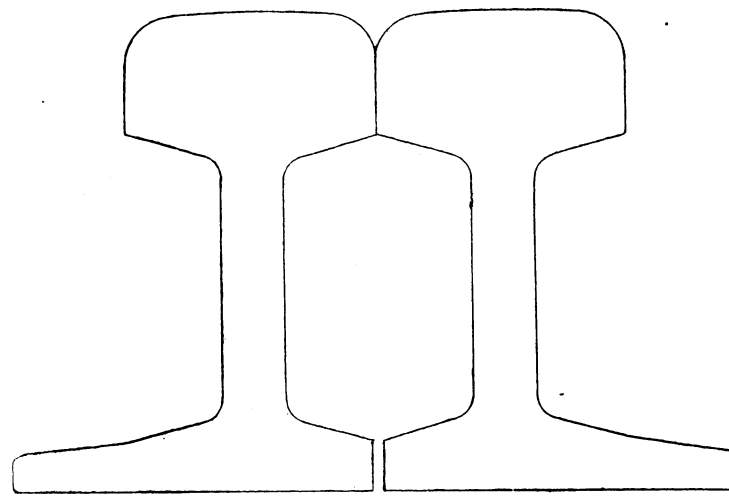

Fig 3  
SECTION BB HALF SIZE

Inches 1 2 3 4 5 6 7 8 9 10 11 12 13 14 15 Feet  
SCALE TO FIG 1