

# NEW SOUTH WALES RAILWAY

III  
179

Planche 27.

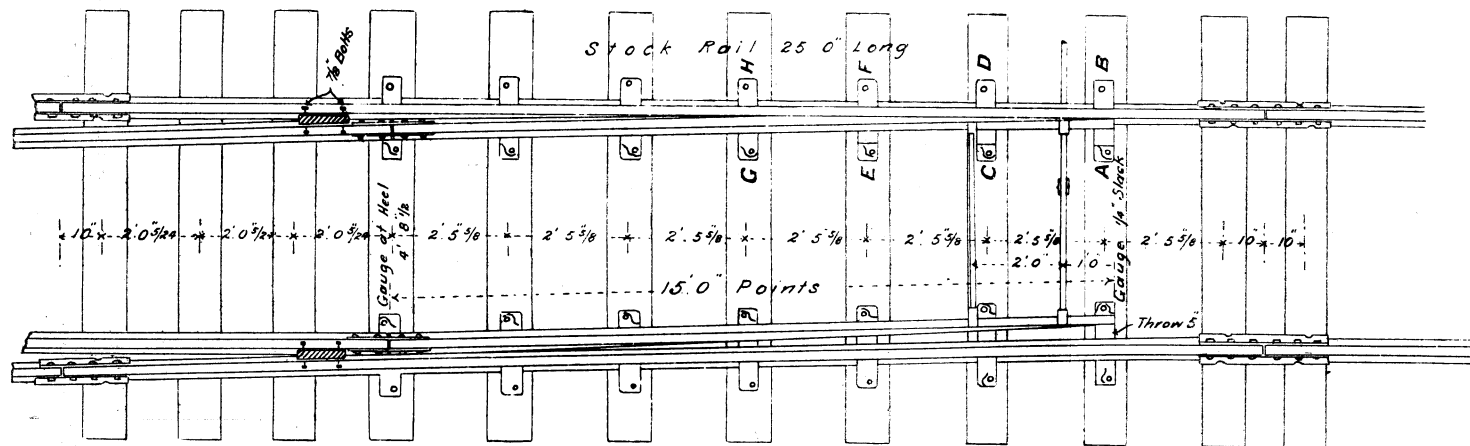

— Fig 1 —  
— 15.0 POINTS AND STOCK RAILS —

— SCALE for 15.0 Points —

Inches 12 6 0 1 2 3 4 5 6 7 8 9 10 11 12 13 14 15 16 17 18 19 20 Feet

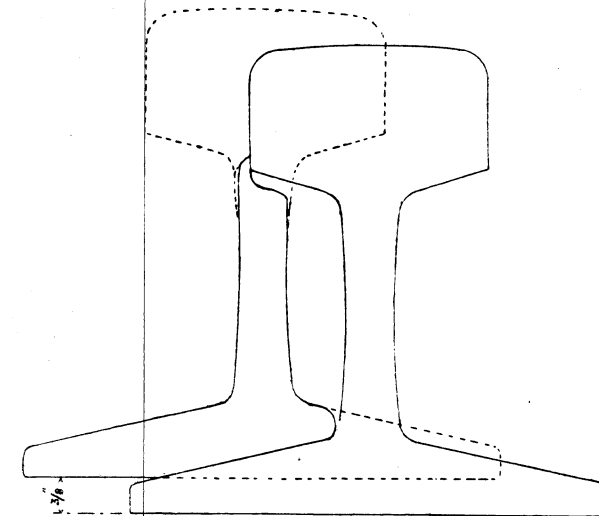

— Fig 2 —  
— SECTION AT AB —  
— TOE OF POINTS —

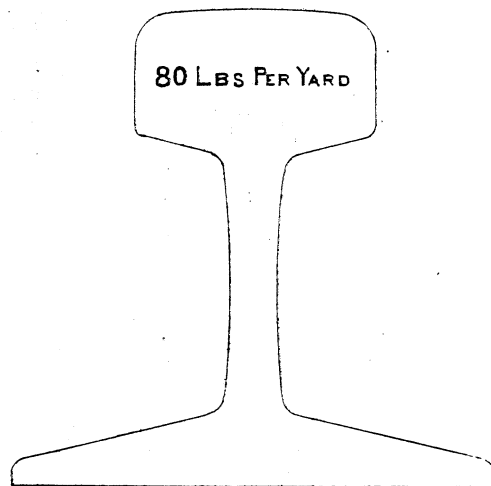

— Fig 3 —  
— RAIL HALF SIZE —

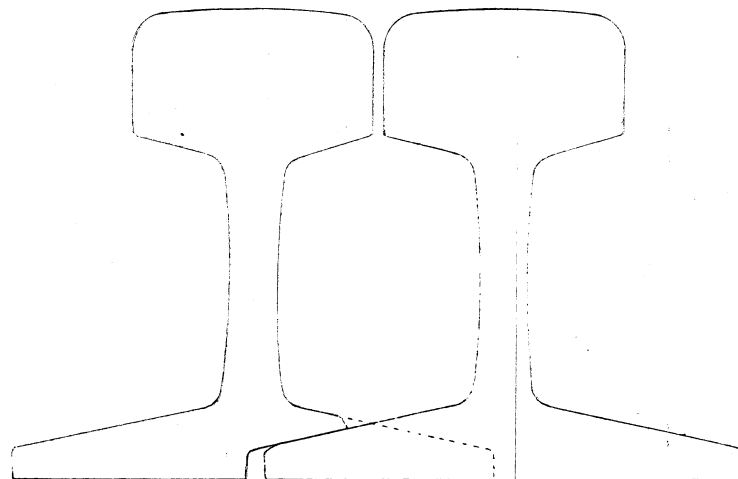

— Fig 4 —  
— SECTION AT GH —

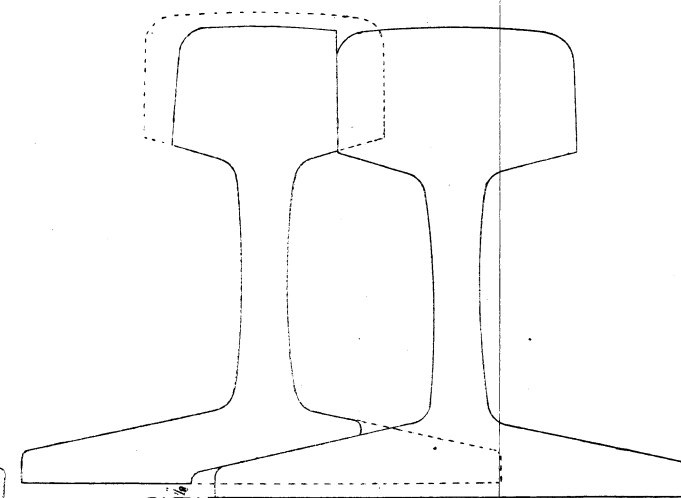

— Fig 5 —  
— SECTION AT EF —

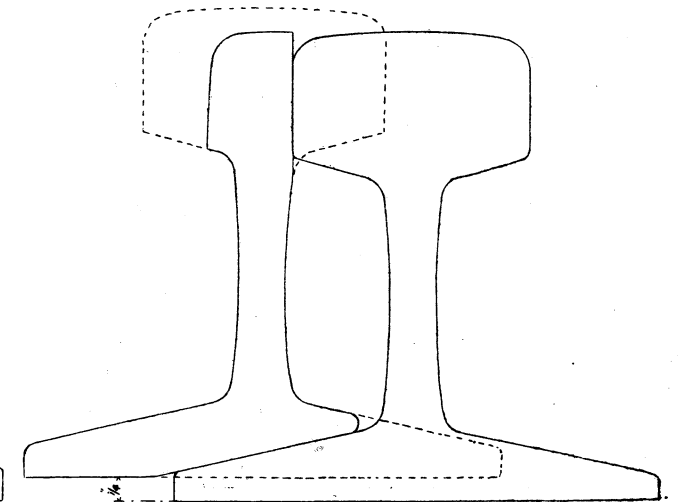

— Fig 6 —  
— SECTION AT CD —

— SECTIONS OF POINTS AND STOCK RAILS —  
— 1/2 FULL SIZE —

*Explication des termes anglais:* — Stock Rail 25.0 Long = Rail contre-aiguille de 7.62 mètres. — 15.0 Points = Aiguille de 4.57 mètres. — 15.0 Points and Stock Rails = Aiguille de 4.57 mètres et rail contre-aiguille. — Toe of Points = Pointe d'aiguille. — Sections of Points and Stock Rails = Sections d'aiguilles et de rails contre-aiguille. — 1/2 Full Size = Demi-grandeur.